



INSTRUCTION BULLETIN

No. 9015630
Machine: M17
Published: 01-2017
Rev. 00

NOTE: DO NOT DISCARD the Parts List from the Instruction Bulletin. Place the Parts List in the appropriate place in the machine manual for future reference. Retaining the Parts List will make it easier to reorder individual parts and will save the cost of ordering an entire kit.

NOTE: Numbers in parenthesis () are reference numbers for parts listed in Bill of Materials.

Installation instructions for **kit number 9015023**

SYNOPSIS:

This kit contains the parts needed to replace the hopper seals on the M17 sweeper scrubber. Please follow step-by-step instructions.

SPECIAL TOOLS / CONSIDERATIONS: NONE

(Estimated time to complete: 30 minutes)

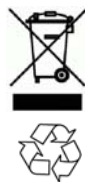

PROTECT THE ENVIRONMENT

Please dispose of packaging materials, used machine components such as batteries and fluids in an environmentally safe way according to local waste disposal regulations.

Always remember to recycle.

PREPARATION:

1. Stop the machine on a level surface and set the parking brake.
2. Completely raise the hopper, turn off the machine, position the hopper support bar onto the support bar stop, turn on the machine, and slowly lower the hopper until the hopper support bar rests on the support bar stop.



WARNING: Lift arm pinch point. Stay clear of hopper lift arms.



WARNING: Raised hopper may fall. Engage hopper support bar.

3. Turn off the machine.

FOR SAFETY: Before leaving or servicing machine, stop on level surface, turn off machine, set parking brake, and remove key.

INSTALLATION:

1. Measure the existing hopper seals on the filter box frame and record the measurements. The new hopper seals will need to be cut to the same lengths. (Fig. 1)

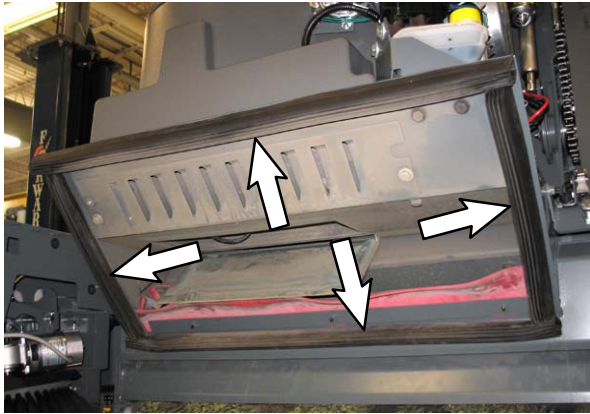

FIG. 1

2. Remove the existing hopper seals from the filter box frame. (Fig. 1)
3. Remove all remaining seal residue where the removed seals were previously located from the filter box frame.
4. Clean the area where the old seals were previously located with alcohol. There should be no remaining residue, dust, or dirt remaining where the removed seals were previously located.

NOTE: There must be no remaining seal residue, dirt, and / or debris remaining on the filter box frame where the new bulb seals (1) / (2) will be installed. Remaining residue, dirt, and / or debris could prevent the new seals from completely adhering to the filter box frame.

5. Cut the longer length of bulb seal from the bulk 96 in. (2438 mm) bulb seal (1) for the top of the filter box frame.
6. Cut the two shorter lengths of bulb seal from the remainder of the bulb seal (1) for the sides of the filter box frame.
7. Install the longer length of bulb seal (1) and the bulb seal (2) onto the filter box frame. (Fig. 4)
8. Cut one edge of each shorter length of bulb seal (1) at angle so the edge will be flush against the top edge of the bulb seal (2) located on the bottom of the filter box frame. (Fig. 4)

9. Install the shorter lengths of bulb seal (1) onto the filter box frame. (Fig. 2 / Fig. 3 / Fig. 4)

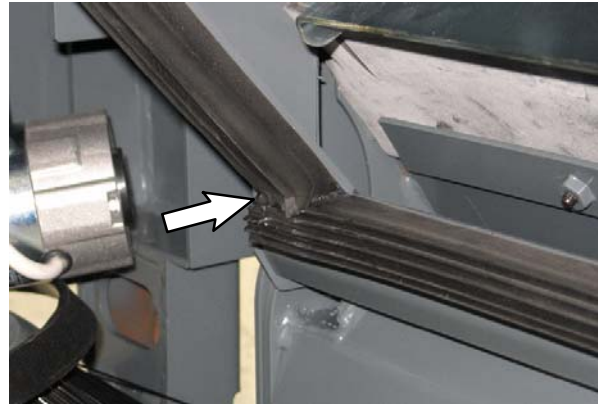

FIG. 2



FIG. 3

10. Use Loctite® 454™ to secure the ends of the shorter bulb seals (1) to the longer bulb seals (1) and (2).
11. Spray accelerant Loctite® 7452™ onto the glued edges of the various lengths of bulb seal (1) and (2) assembled in the previous step.
12. Test the machine. Ensure the entire surface of each seal joint made to the various lengths of seal bulb (1) and (2) in the previous several steps is fully adhered.
13. Start the machine, completely raise the hopper, disengage the hopper support bar, and lower the hopper.

Loctite® 454™ and Loctite® 7452™ are registered trademarks of the Henkel Corporation

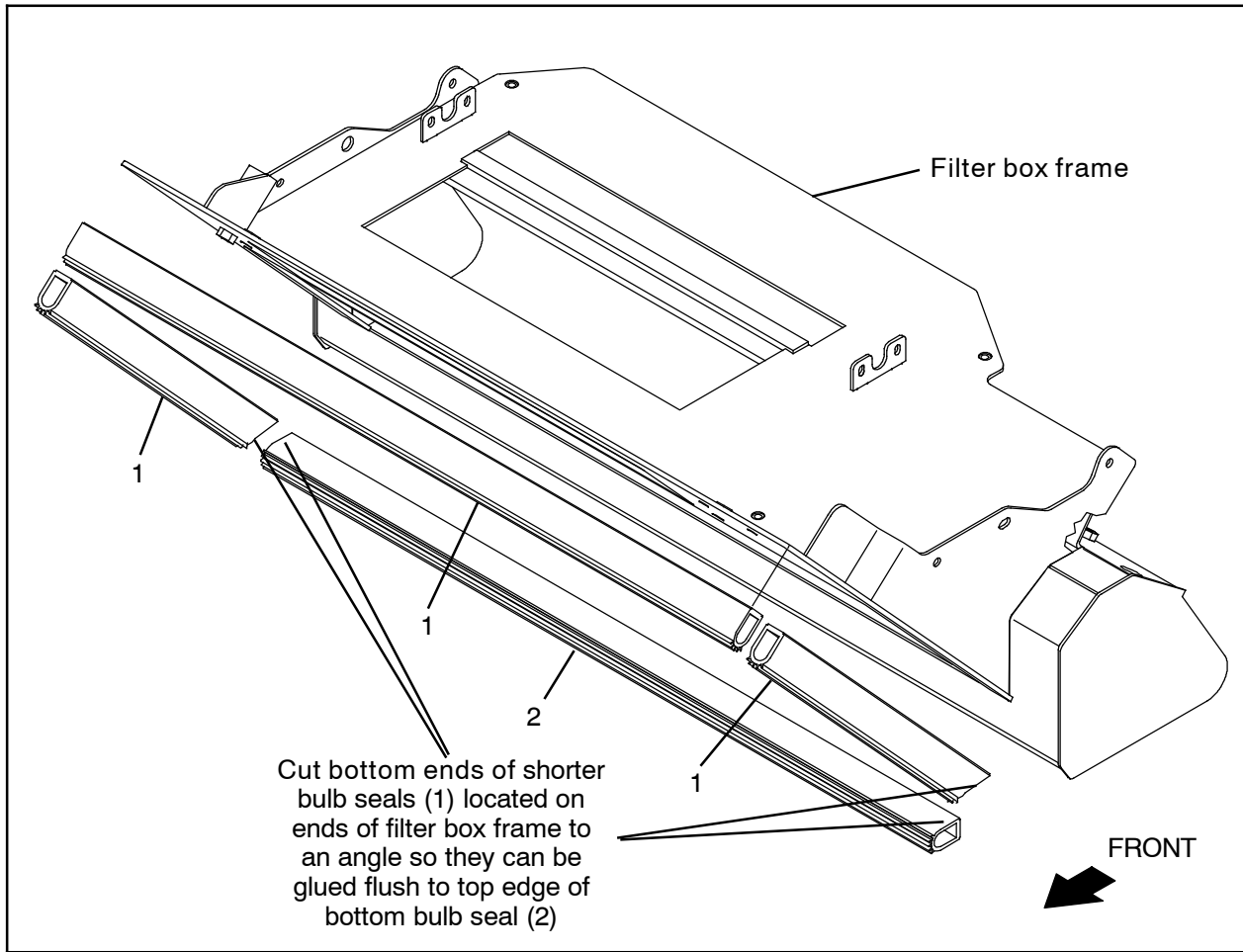

Bill Of Materials For Seal Kit, Hppr, Afmkt [M17] - 9015023

Ref.	Tennant Part No.	Description	Qty.
1	1226821	Seal, Bulb, Str, 1.12H .88W Adh, Bulk (8 ft)	1
2	1226827	Seal, Bulb, Str, 1.51H .88W Adh, 32.6L	1

TENNANT COMPANY
 P. O. Box 1452
 Minneapolis, MN 55440-1452